

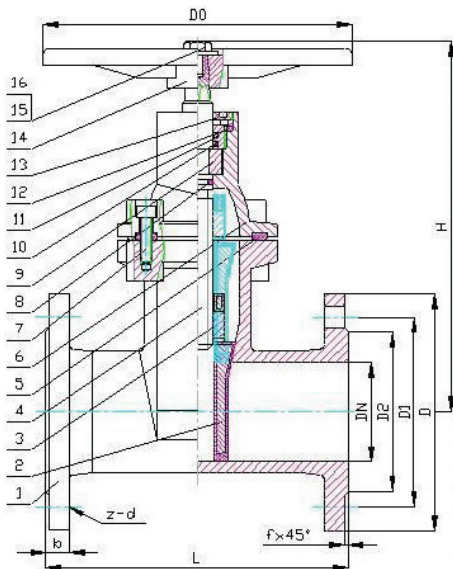

CAST IRON VALVES

GENEBRE PART: 2102 FLANGED DUCTILE IRON GATE VALVE PN16



SPECIFICATIONS

1	Material Cast Iron GGG-50, epoxy coated
2	Mounting: PN16 flanges
3	Max working pressure 16 Bar
4	Max Temperature + 80°C
5	Non-rising stem
6	EPDM coated wedge
7	Full flow, reduced head losses
8	Bi-directional flow
9	Designed for use with water

MATERIALS

1	Ductile Iron GGG-50, epoxy coated
2	Ductile Iron GGG-40 EPDM coated
3	Brass
4	AISI 410
5	EPDM
6	Ductile Iron GGG-50, epoxy coated
14	Epoxy coated steel

DIMENSIONS

AVOL	SIZE	H	L	D	Wt
REF		mm	mm	mm	Kg
2102 09	2"	240	150	165	11.6
2102 10	2 1/2"	270	170	185	15.8
2102 11	3"	300	180	200	17.5
2102 12	4"	330	190	220	22.8
2102 13	5"	375	200	250	34.4
2102 14	6"	425	210	285	44.8
2102 16	8"	515	230	340	56.8
2102 18	10"	600	250	400	100.0
2102 20	12"	685	270	455	140.0

Kv Values

DN 50	DN 65	DN 80	DN 100	DN 125	DN 150	DN 200	DN 250	DN 300
250	410	590	1050	1850	2620	4850	7600	11200